

Numerical Questions

Computer Networks(CS31204)

Prof. Sudip Misra

Department of Computer Science and Engineering

Indian Institute of Technology Kharagpur

Email: smisra@sit.iitkgp.ernet.in

Website: <http://cse.iitkgp.ac.in/~smisra/>

Research Lab: cse.iitkgp.ac.in/~smisra/swan/



Question No. 1



Bit-stuff the following frame payload:

0001111111001111101000111111111110000111

Solution



00011111110011111010001111111111110000111

0001111110110011111001000111111011111110000111

Question No. 2



Unstuff the following frame payload:

```
00011111000001111101110100111011111000001111
```

Solution



000111110000011111011101001110111111000001111

0001111100001111111010011101111100001111

Question No. 3



Draw figure using the following scenario:

- a.** The first frame is sent and acknowledged.
- b.** The second frame is sent and acknowledged, but the acknowledgment is lost.
- c.** The second frame is resent, but it is timed-out.
- d.** The second frame is resent and acknowledged.

Solution

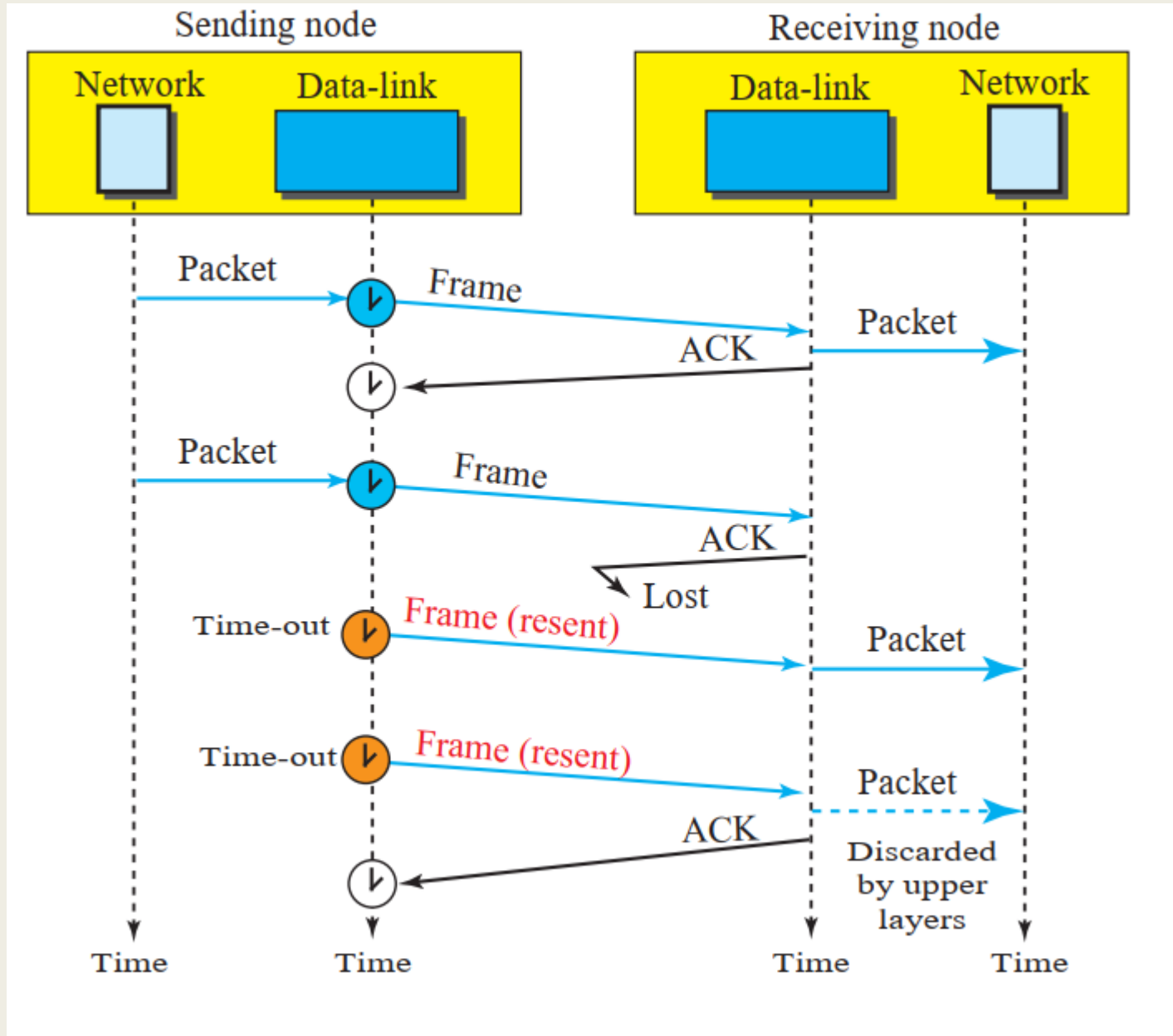

Question No. 4



Draw figure using the following scenario:

- a. Frame 0 is sent, but lost.
- b. Frame 0 is resent and acknowledged.
- c. Frame 1 is sent and acknowledged, but the acknowledgment is lost.
- d. Frame 1 is resent and acknowledged.

Solution

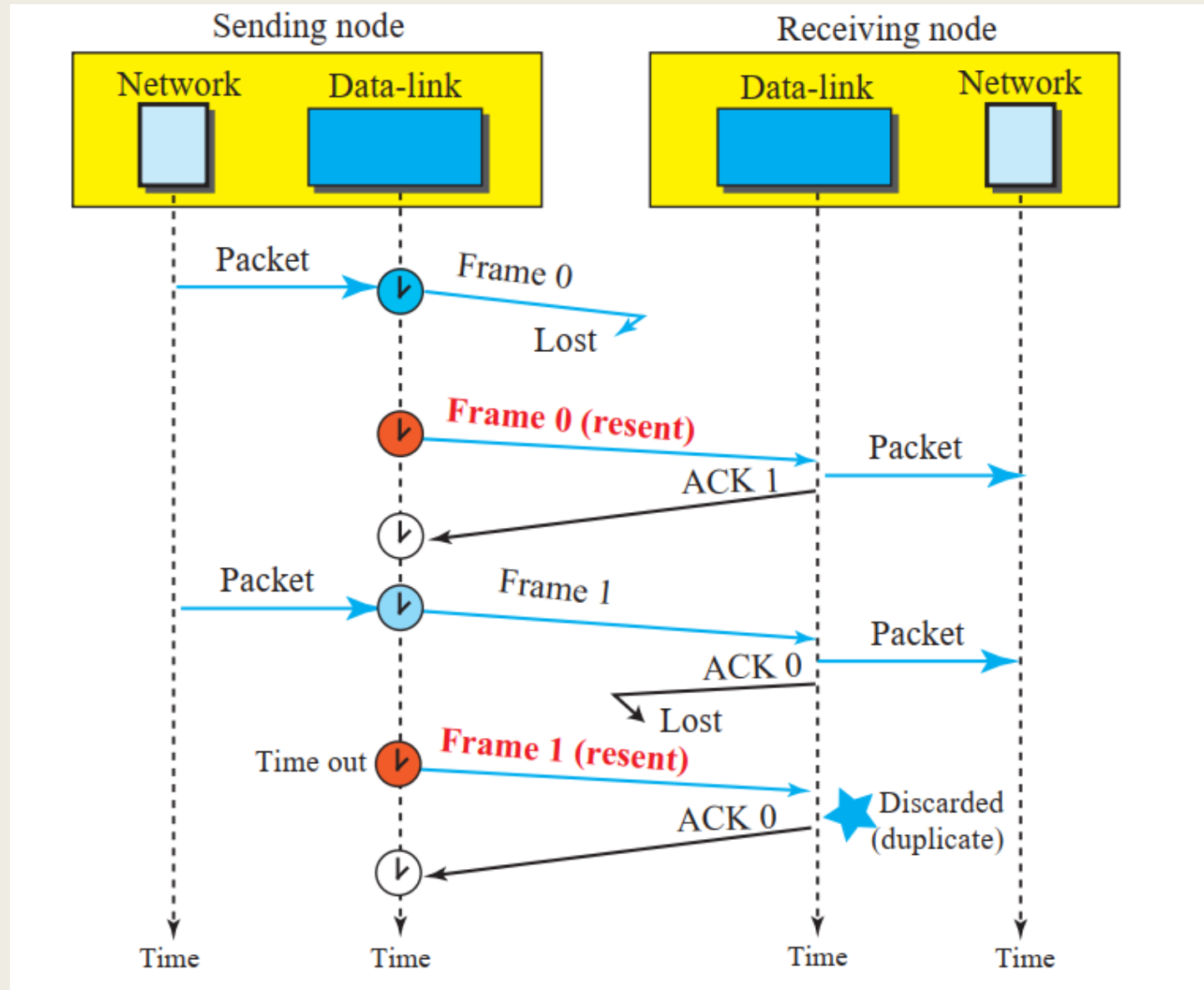

Question No. 5



Assume that a voice channel occupies a bandwidth of 4 kHz. We need to multiplex 10 voice channels with guard bands of 500 Hz using FDM. Calculate the required bandwidth.

Solution



To multiplex 10 voice channels, we need nine guard bands. The required bandwidth is then $B = (4 \text{ KHz}) \times 10 + (500 \text{ Hz}) \times 9 = 44.5 \text{ KHz}$

Question No. 6



We need to transmit 100 digitized voice channels using a passband channel of 20 KHz. Each digitized voice channel has a data rate of 64 Kbps. What should be the ratio of bits/Hz if we use no guard band?

Solution



The bandwidth allocated to each voice channel is $20 \text{ KHz} / 100 = 200 \text{ Hz}$. Each digitized voice channel has a data rate of 64 Kbps . This means that our modulation technique uses $64,000/200 = 320 \text{ bits/Hz}$.

Question No. 7



We need to use synchronous TDM and combine 20 digital sources, each of 100 Kbps. Each output slot carries 1 bit from each digital source, but one extra bit is added to each frame for synchronization. Answer the following questions:

- a. What is the size of an output frame in bits?
- b. What is the output frame rate?
- c. What is the duration of an output frame?
- d. What is the output data rate?
- e. What is the efficiency of the system (ratio of useful bits to the total bits)?

Solution



- a. Each output frame carries 1 bit from each source plus one extra bit for synchronization. Frame size = $20 \times 1 + 1 = 21$ bits.
- b. Each frame carries 1 bit from each source. Frame rate = 100,000 frames/s.
- c. Frame duration = $1 / (\text{frame rate}) = 1 / 100,000 = 10$ ms.
- d. Data rate = $(100,000 \text{ frames/s}) \times (21 \text{ bits/frame}) = 2.1$ Mbps
- e. In each frame 20 bits out of 21 are useful. Efficiency = $20/21 = 95\%$



Question No. 8

We have 14 sources, each creating 500 8-bit characters per second. Since only some of these sources are active at any moment, we use statistical TDM to combine these sources using character interleaving. Each frame carries 6 slots at a time, but we need to add 4-bit addresses to each slot. Answer the following questions:

- a. What is the size of an output frame in bits?
- b. What is the output frame rate?
- c. What is the duration of an output frame?
- d. What is the output data rate?



Solution

- a. Frame size = $6 \times (8 + 4) = 72$ bits.
- b. We can assume that we have only 6 input lines. Each frame needs to carry one character from each of these lines. This means that the frame rate is 500 frames/s.
- c. Frame duration = $1 / (\text{frame rate}) = 1 / 500 = 2$ ms.
- d. Data rate = $(500 \text{ frames/s}) \times (72 \text{ bits/frame}) = 36$ kbps.

Question No. 9



Four channels are multiplexed using TDM. If each channel sends 100 bytes/s and we multiplex 1 byte per channel, show the frame traveling on the link, the size of the frame, the duration of a frame, the frame rate, and the bit rate for the link.



Solution

Each frame carries 1 byte from each channel; the size of each frame, therefore, is 4 bytes, or 32 bits. Because each channel is sending 100 bytes/s and a frame carries 1 byte from each channel, the frame rate must be 100 frames per second. The duration of a frame is therefore $1/100$ s. The link is carrying 100 frames per second, and since each frame contains 32 bits, the bit rate is 100×32 , or 3200 bps. This is actually 4 times the bit rate of each channel, which is $100 \times 8 = 800$ bps.

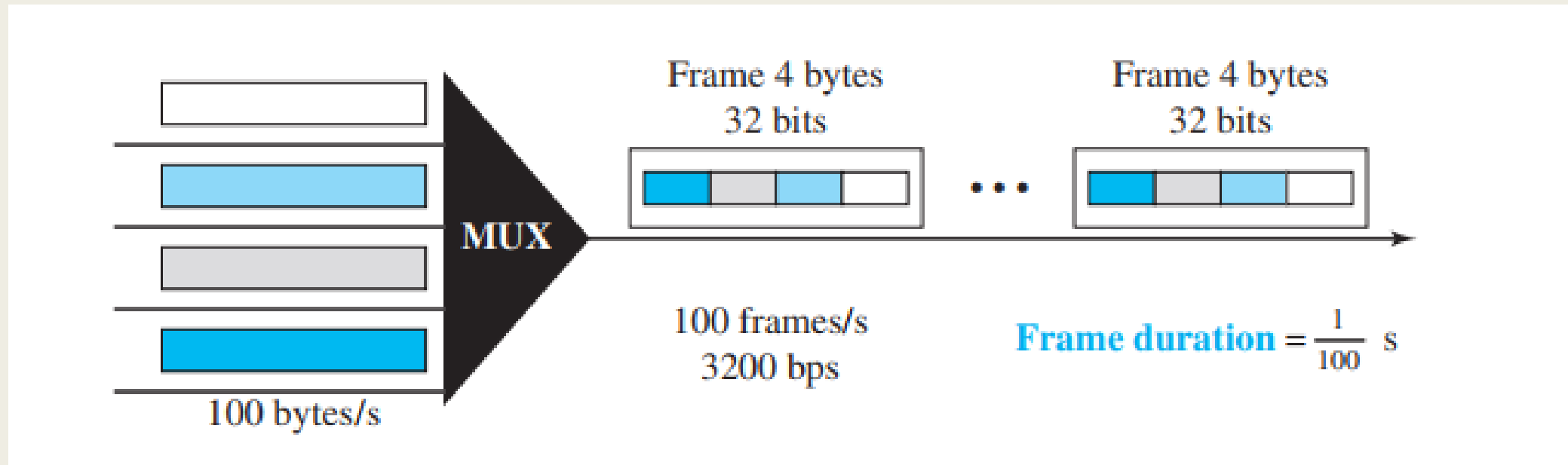

Question No. 10



Suppose a device in a pure Aloha network is transmitting packets of data that are 1,000 bits in length. The speed of 500m channel is 2×10^8 m/s. What is the vulnerable time of the device's transmission?



Solution

$$\text{Vulnerable Time} = 2 * (\text{Distance}) / (\text{Speed})$$

$$\text{Vulnerable Time} = 2 * (500\text{m}) / (2 * 10^8) = 5\mu\text{s}$$

So the vulnerable time of the device's transmission is $5\mu\text{s}$.

Question No. 11



Suppose a device in a slotted Aloha network is transmitting packets of data that are 1,000 bits in length. The speed of 1 km channel is 2×10^8 m/s. What is the vulnerable time of the device's transmission?



Solution

Vulnerable Time = Propagation Time = Distance / Speed

$$\text{Vulnerable Time} = (1000\text{m}) / (2 * 10^8) = 5\mu\text{s}$$

So the vulnerable time of the device's transmission is $5\mu\text{s}$.

Question No. 12



In a pure Aloha network with $G = 1/2$, how is the throughput affected in each of the following cases?

- a. G is increased to 1.
- b. G is decreased to $1/4$.

Solution



In a pure Aloha, the throughput at $G = 1/2$ is 18.4% (maximum value).

- a. When $G = 1$, the throughput is decreased to 13.5%.
- b. When $G = 1/4$, the throughput is decreased to 15.2%.



Question No.13

Assume the propagation delay in a broadcast network is $5 \mu\text{s}$ and the frame transmission time is $10 \mu\text{s}$.

- a. How long does it take for the first bit to reach the destination?
- b. How long does it take for the last bit to reach the destination after the first bit has arrived?
- c. How long is the network involved with this frame (vulnerable to collision)?

Solution



The last bit is $10 \mu\text{s}$ behind the first bit.

- a. It takes $5 \mu\text{s}$ for the first bit to reach the destination.
- b. The last bit arrives at the destination $10 \mu\text{s}$ after the first bit.
- c. The network is involved with this frame for $5 + 10 = 15 \mu\text{s}$.



Thank You!!!