

Transmission Modes

Computer Networks(CS31204)

Prof. Sudip Misra

Department of Computer Science and Engineering

Indian Institute of Technology Kharagpur

Email: smisra@sit.iitkgp.ernet.in

Website: <http://cse.iitkgp.ac.in/~smisra/>

Research Lab: cse.iitkgp.ac.in/~smisra/swan/





Issues of Reliable Data Transfer between Two Machines

- Synchronization: How does the receiver know when the sender is sending data?
- Encoding: Representing data with signals
- Error control: How to ensure the receiver gets the correct data
- Flow control: How to ensure the sender does not swamp the receiver (fast sender, slow receiver)

Synchronization



Basic steps in transmitting digital data:

- ❑ Transmitter sends a stream of 0 or 1 bits
- ❑ Receiver samples incoming signal **once per bit time** to see if it is a 0 or
- ❑ Typically at the center of the bit

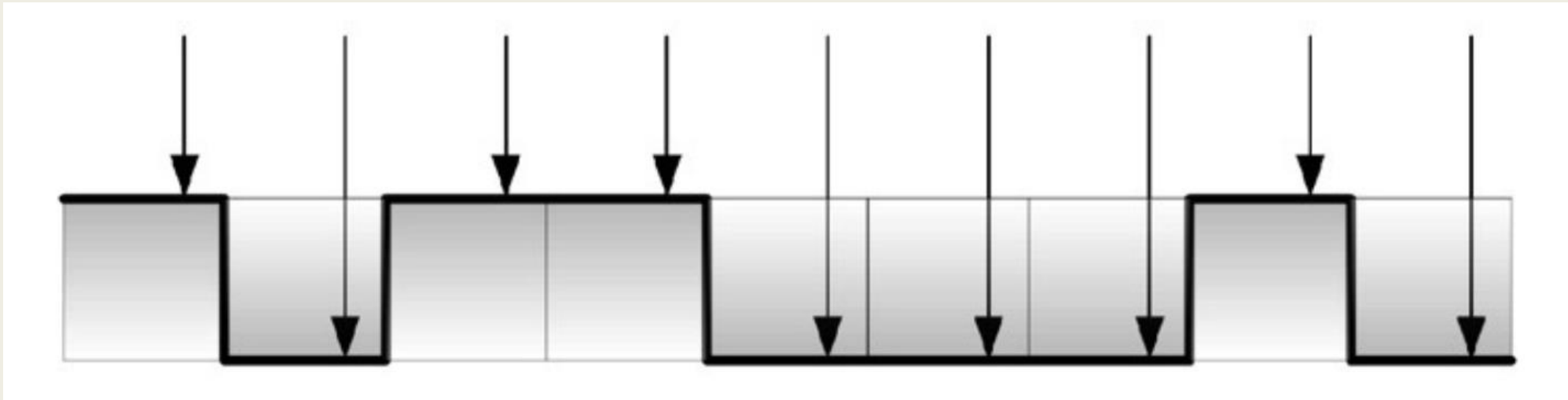



Contd...

Transmitter sends one bit (0 or 1) every 1 millisecond (say)

Say there is a clock that ticks every 1 millisecond

Transmitter puts a 1 or 0 on the line at each tick of the clock bit 1 on tick 1, bit 2 on tick 2, ...

What should the receiver do to get the pattern correctly?

Need to know when to start counting (when will bit 1 arrive)

A-priori agreed or sender has to tell (how?)

Need to know when to look for the next successive bits (duration of one bit) and how to send data.



Transmission Modes

The transmission of binary data across a link can be accomplished in either parallel or serial mode. In parallel mode, multiple bits are sent with each clock tick. In serial mode, 1 bit is sent with each clock tick. While there is only one way to send parallel data, there are three subclasses of serial transmission: asynchronous, synchronous, and isochronous.

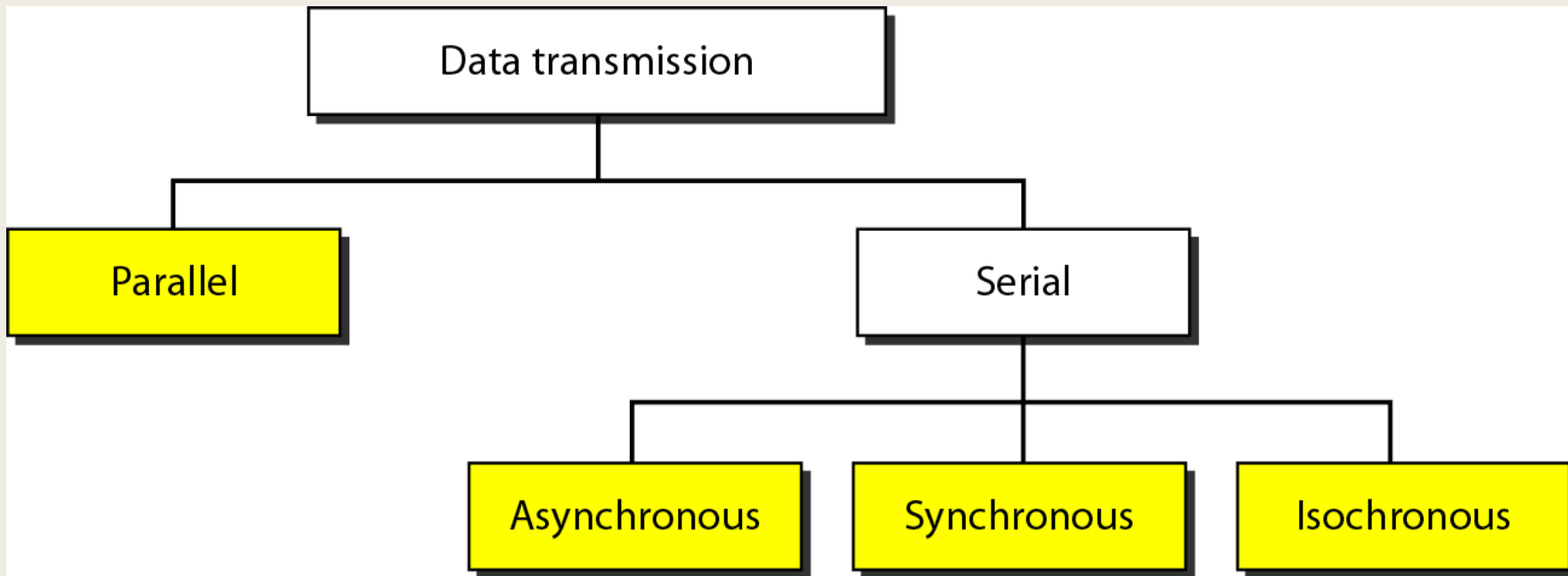

Source: B. A. Forouzan, "Data Communications and Networking," McGraw-Hill Forouzan Networking Series, 5E.

Parallel transmission

Use n wires to send n bits at one time.

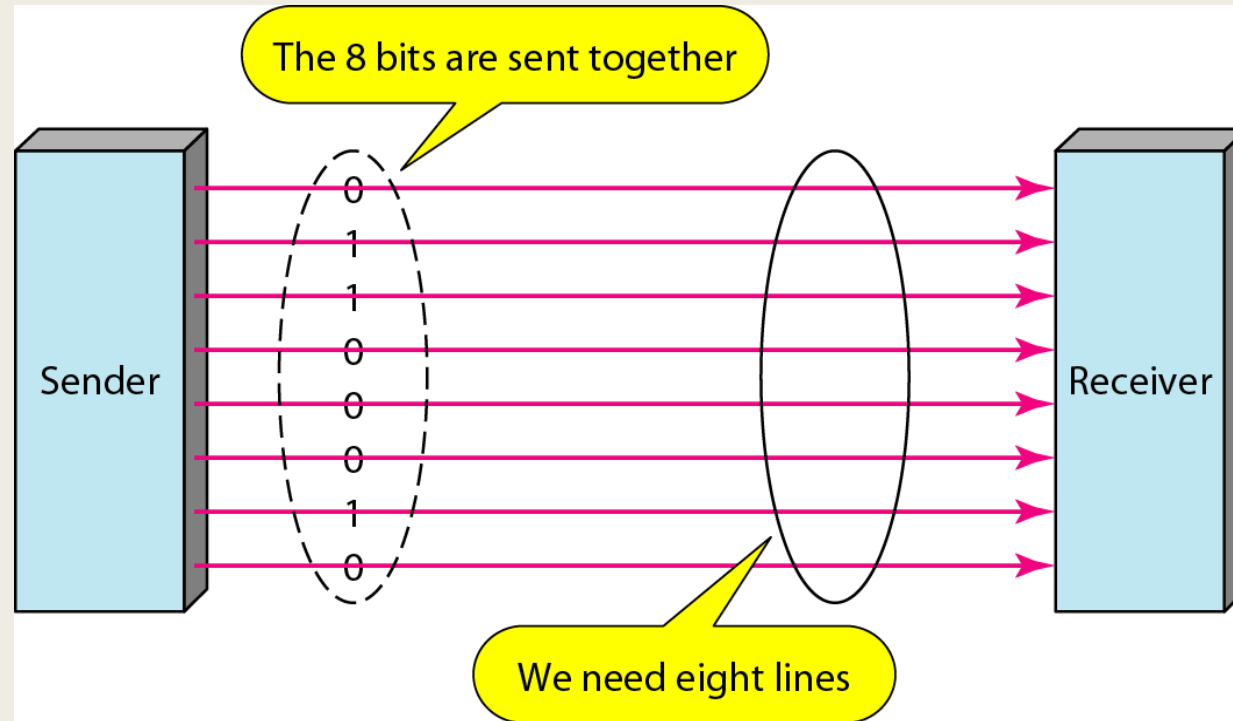

Serial transmission

In serial transmission one bit follows another, so we need only one communication channel rather than n to transmit data between two communicating devices

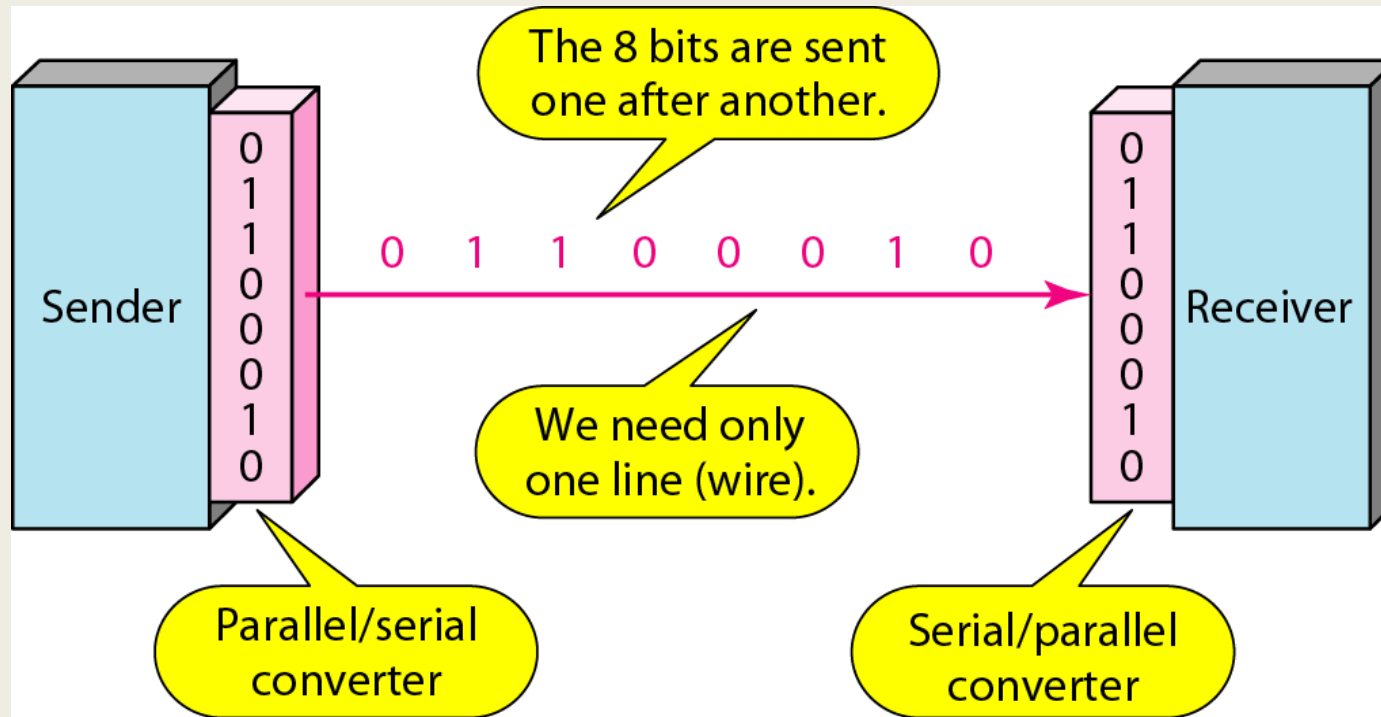

Source: B. A. Forouzan, "Data Communications and Networking," McGraw-Hill Forouzan Networking Series, 5E.

Asynchronous transmission

In asynchronous transmission, we send 1 start bit (0) at the beginning and 1 or more stop bits (1s) at the end of each byte. There may be a gap between each byte.

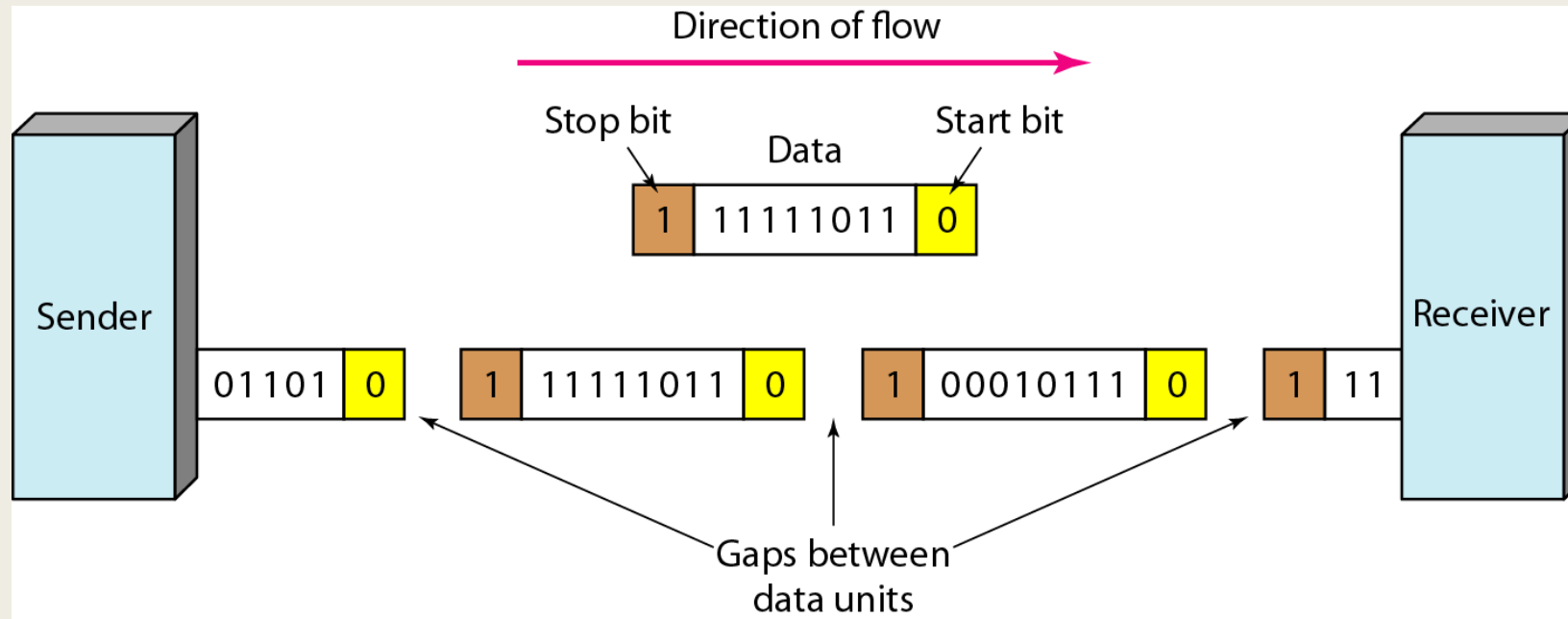

Synchronous transmission

- In synchronous transmission, we send bits one after another without start or stop bits or gaps.
- It is the responsibility of the receiver to group the bits.
- The bits are usually sent as bytes and many bytes are grouped in a frame.
- A frame is identified with a start and an end byte.

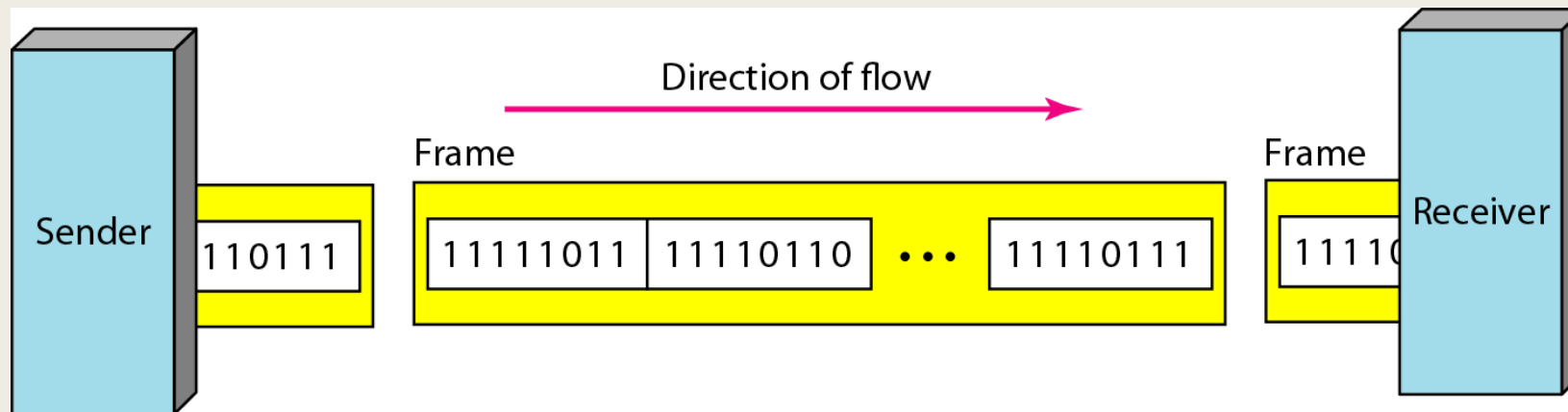

Source: B. A. Forouzan, " Data Communications and Networking ," McGraw-Hill Forouzan Networking Series,5E.



Isochronous

- In isochronous transmission we cannot have uneven gaps between frames.
- Transmission of bits is fixed with equal gaps.



Line Encoding

- Considerations for choosing a good signal element referred to as **line encoding**.

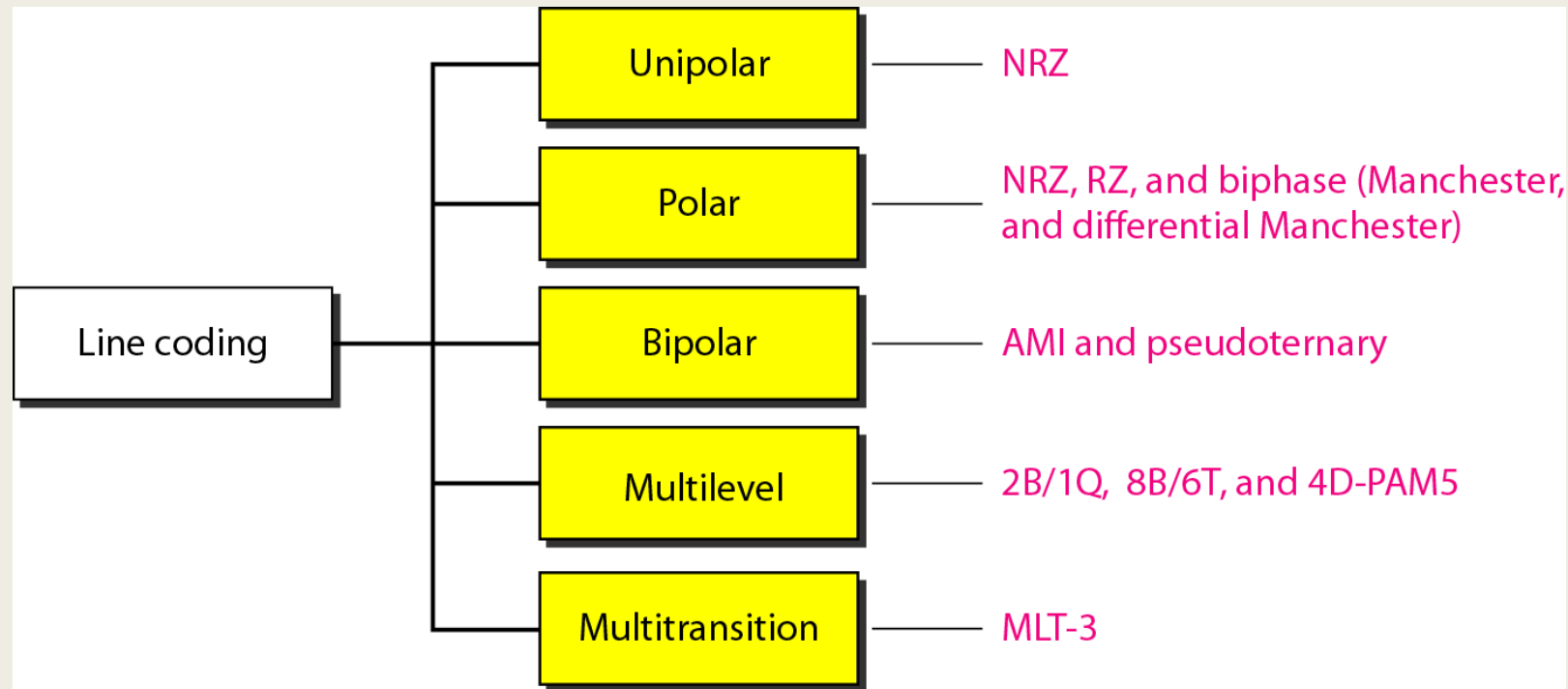

Source: B. A. Forouzan, "Data Communications and Networking," McGraw-Hill Forouzan Networking Series, 5E.



Unipolar

- All signal levels are on one side of the time axis - either above or below
- NRZ - Non Return to Zero scheme is an example of this code. The signal level does not return to zero during a symbol transmission.
- Scheme is prone to baseline wandering and DC components. It has no synchronization or any error detection. It is simple but costly in power consumption.

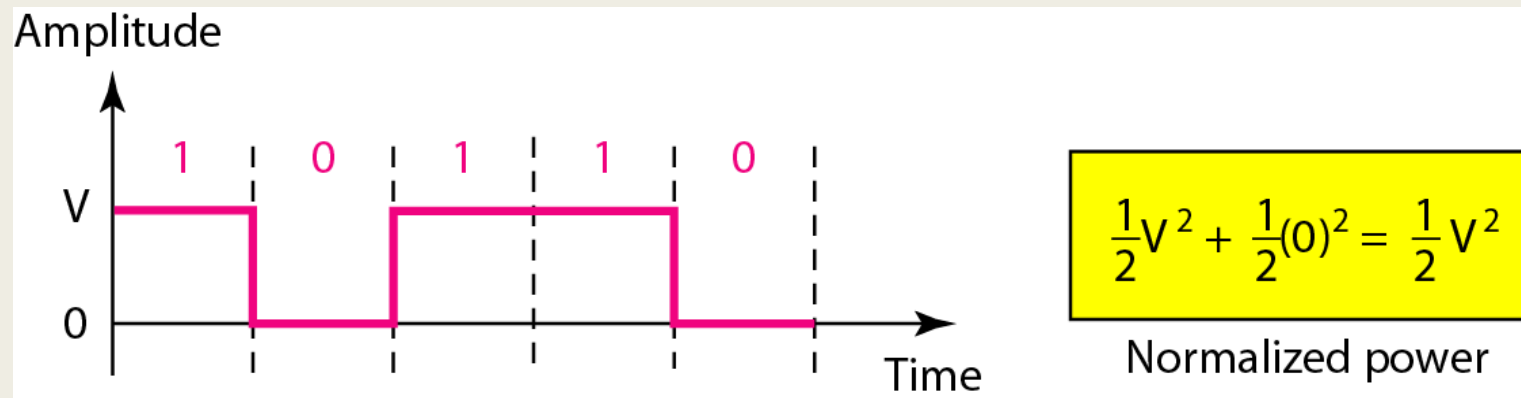

Polar - NRZ

- The voltages are on both sides of the time axis.
- Polar NRZ scheme can be implemented with two voltages. E.g. +V for 1 and -V for 0.
- There are two versions:
 - NRZ - Level (NRZ-L) - positive voltage for one symbol and negative for the other
 - NRZ - Inversion (NRZ-I) - the change or lack of change in polarity determines the value of a symbol. E.g. a “1” symbol inverts the polarity a “0” does not.

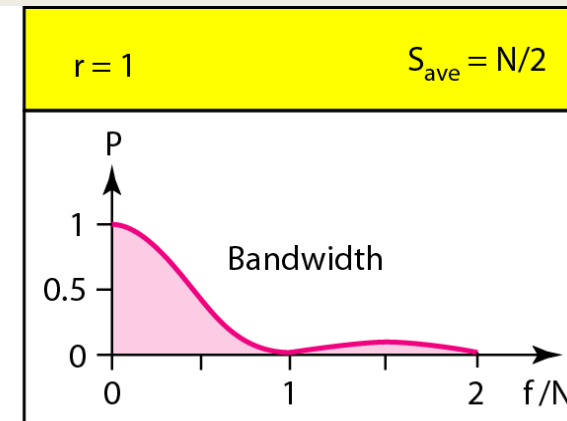
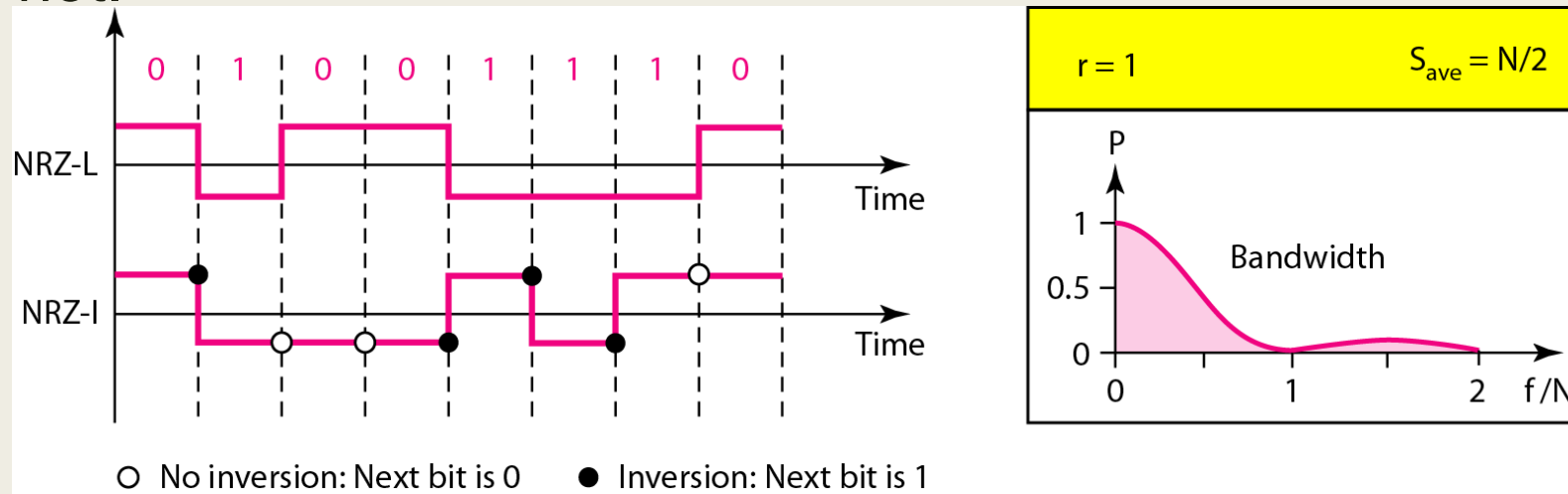

Source: B. A. Forouzan, "Data Communications and Networking," McGraw-Hill Forouzan Networking Series, 5E.



Polar - RZ

- The Return to Zero (RZ) scheme uses three voltage values. +, 0, -.
- Each symbol has a transition in the middle. Either from high to zero or from low to zero.
- This scheme has more signal transitions (two per symbol) and therefore requires a wider bandwidth.
- No DC components or baseline wandering.
- Self synchronization - transition indicates symbol value.
- More complex as it uses three voltage level. It has no error detection capability.

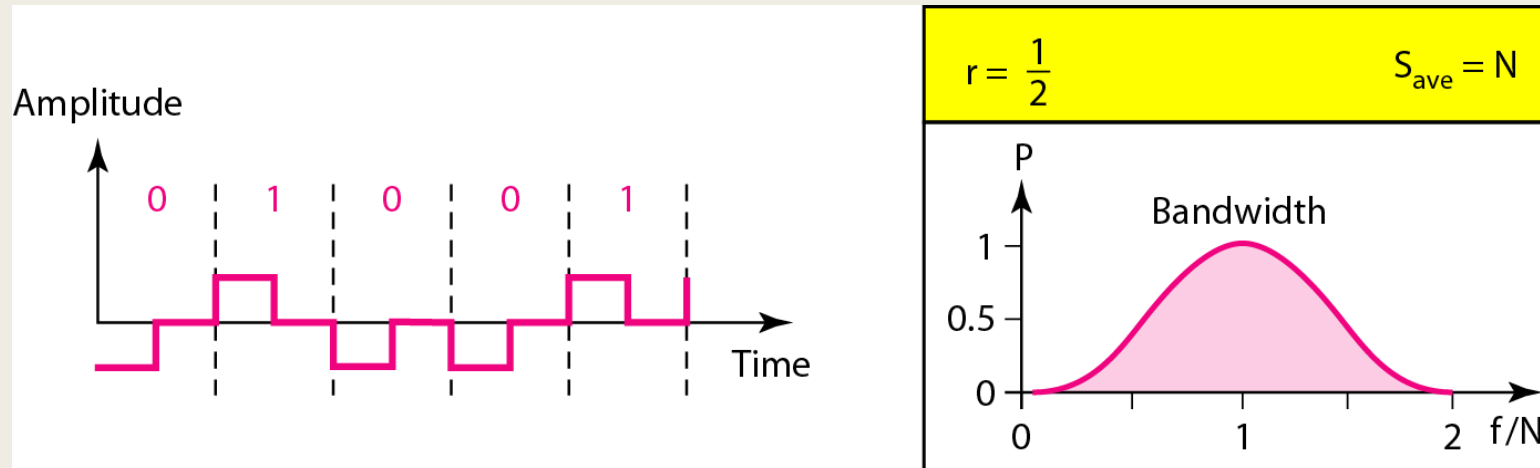

Source: B. A. Forouzan, "Data Communications and Networking," McGraw-Hill Forouzan Networking Series, 5E.

Polar - Biphase: Manchester and Differential Manchester

- Manchester coding consists of combining the NRZ-L and RZ schemes.
 - Every symbol has a level transition in the middle: from high to low or low to high. Uses only two voltage levels.
- Differential Manchester coding consists of combining the NRZ-I and RZ schemes.
 - Every symbol has a level transition in the middle. But the level at the beginning of the symbol is determined by the symbol value. One symbol causes a level change the other does not.

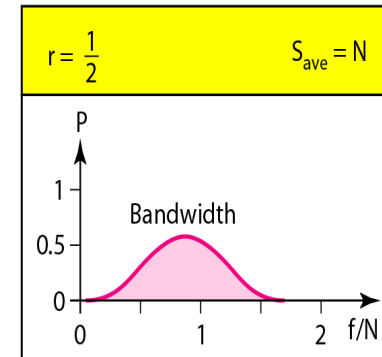
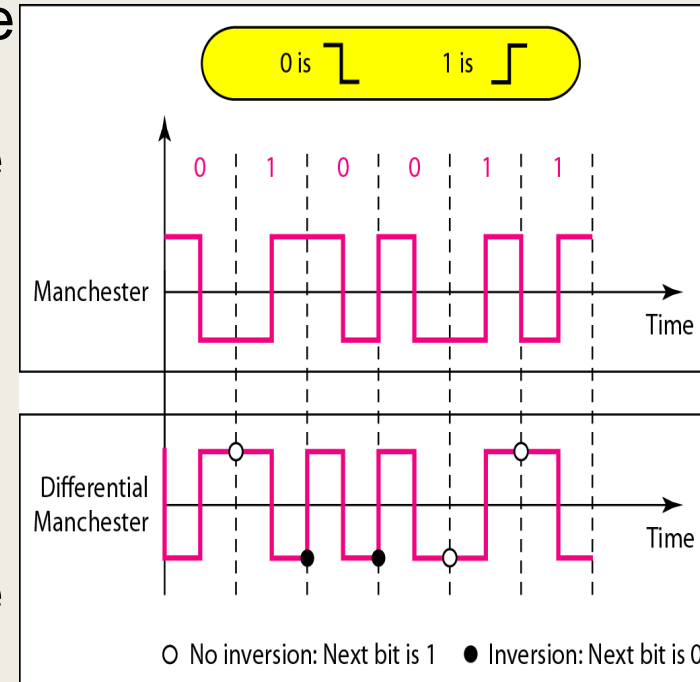



Block Coding

- For a code to be capable of error detection, we need to add redundancy, i.e., extra bits to the data bits.
- Synchronization also requires redundancy - transitions are important in the signal flow and must occur frequently.
- Block coding is done in three steps: division, substitution and combination.
- It is distinguished from multilevel coding by use of the slash - $x\text{B}/y\text{B}$.
- The resulting bit stream prevents certain bit combinations that when used with line encoding would result in DC components or poor sync. quality.

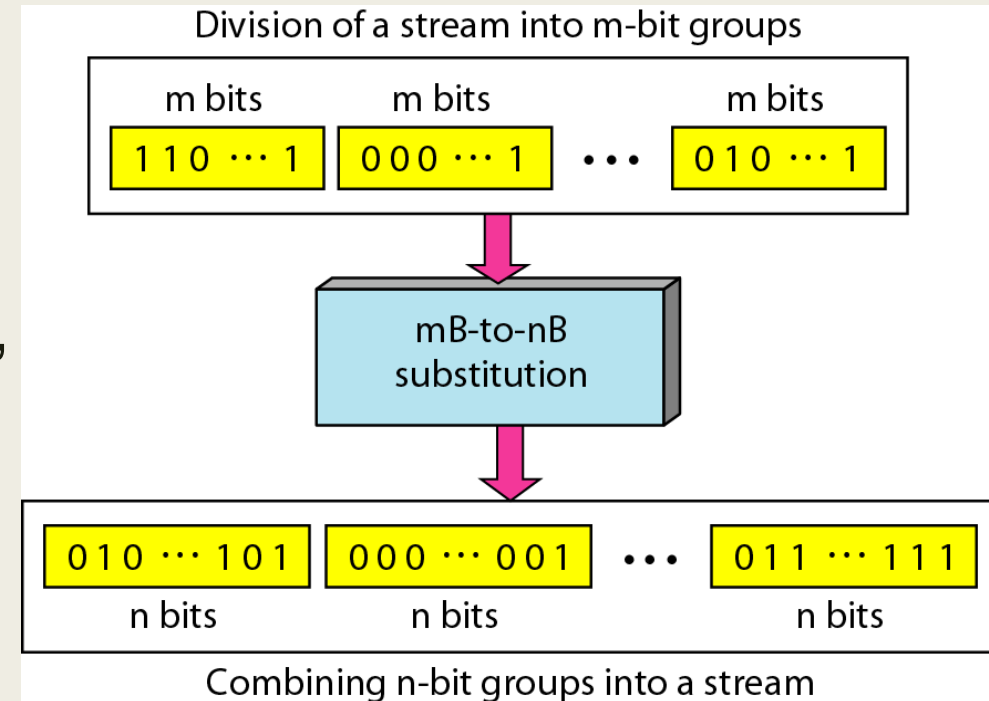

4B/5B

In 4B/5B encoding:

- Initially, input bit sequence is divided into 4 bit groups.
- The 4 bit group is now substituted with 5 bit group as per table.
- Finally, n-bit groups are combined to form output stream.
- Designed to work along with NRZ-I line coding.
- NRZ-I offers better signal rate which is (1/2) of biphase but it suffers from synchronization issue.
- This issue is solved by incorporating 4B/5B before NRZ-I encoder

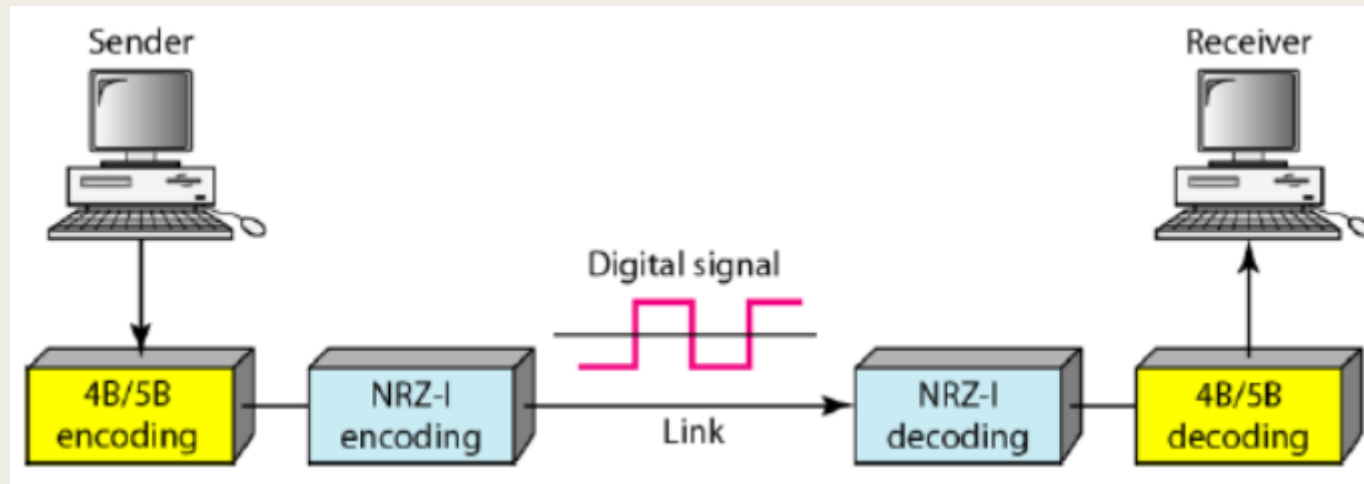

Source: B. A. Forouzan, " Data Communications and Networking ," McGraw-Hill Forouzan Networking Series,5E.

8B/10B



- Uses redundancy to ensure synchronization and to improve performance of this line coding.
- It offers inherent error detection capability.
- The 8B/10B indicates that this block coding takes 8 bit blocks as input and produces 10 bit blocks as output.
- The MSBs of 8 bit block is fed into 5B/6B encoder where as 3 LSBs is fed into 3B/4B encoder modules.
- The coding has $2^{10} - s^8$ redundant groups.
- The 8B/10B block coding is a combination of 5B/6B and 3B/4B encoding.

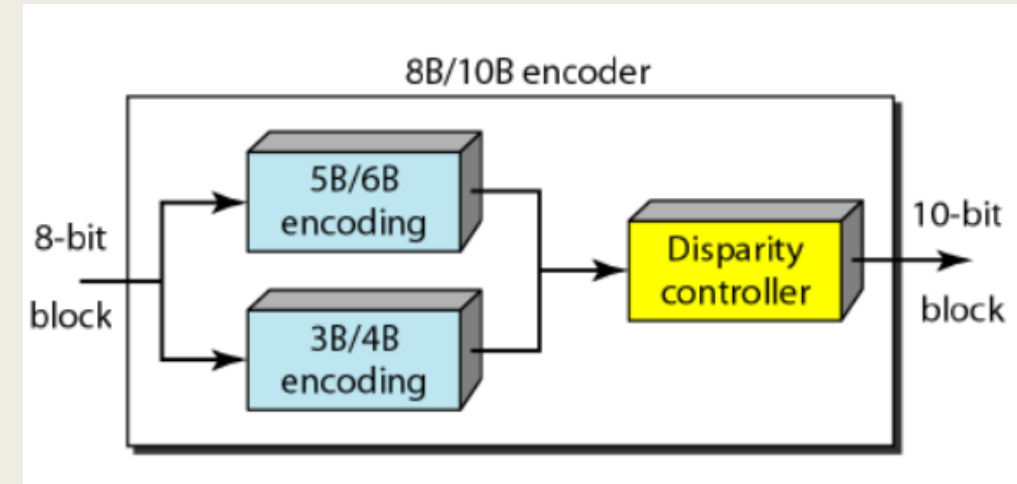

Analog to Digital Conversion



A digital signal is superior to an analog signal because it is more robust to noise and can easily be recovered, corrected and amplified.

For this reason, the tendency today is to change an analog signal to digital data.



Digital to Digital Conversion

The conversion involves three techniques: line coding, block coding, and scrambling.

Line Coding: Converting a string of 1's and 0's (digital data) into a sequence of signals that denote the 1's and 0's.

For example: A high voltage level (+V) could represent a "1" and a low voltage level (0 or -V) could represent a "0".

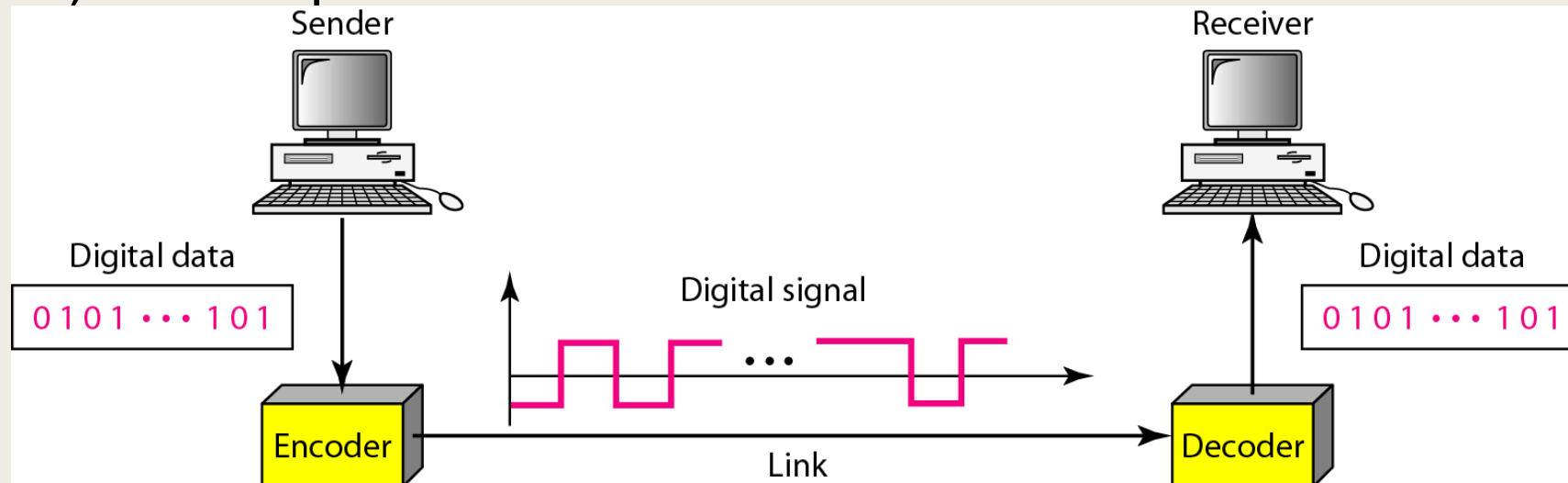

Source: B. A. Forouzan, "Data Communications and Networking," McGraw-Hill Forouzan Networking Series, 5E.



Relationship between data rate and signal rate

- The data rate defines the number of bits sent per sec - bps. It is often referred to the bit rate.
- The signal rate is the number of signal elements sent in a second and is measured in bauds. It is also referred to as the modulation rate.

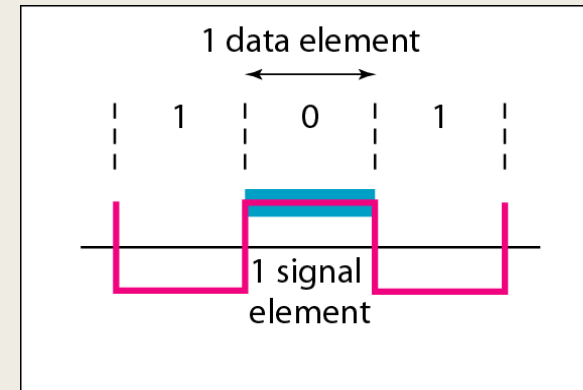

a. One data element per one signal element ($r = 1$)

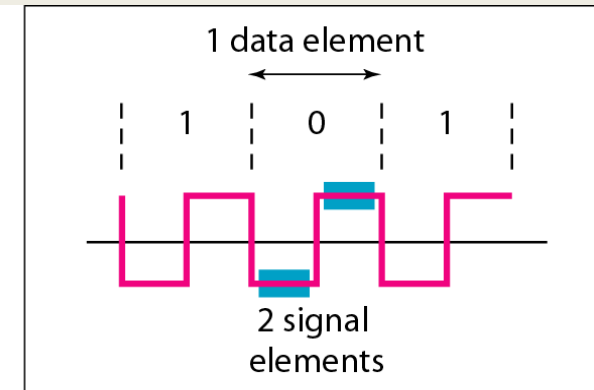

b. One data element per two signal elements ($r = \frac{1}{2}$)

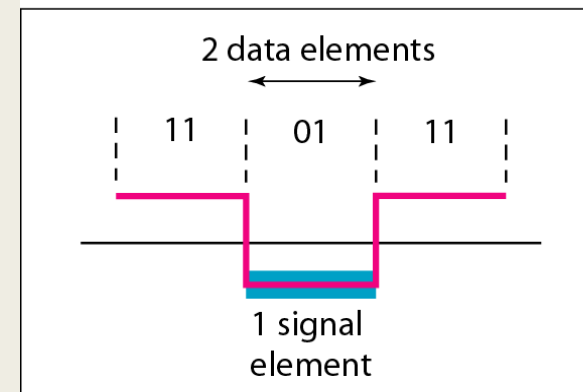

c. Two data elements per one signal element ($r = 2$)

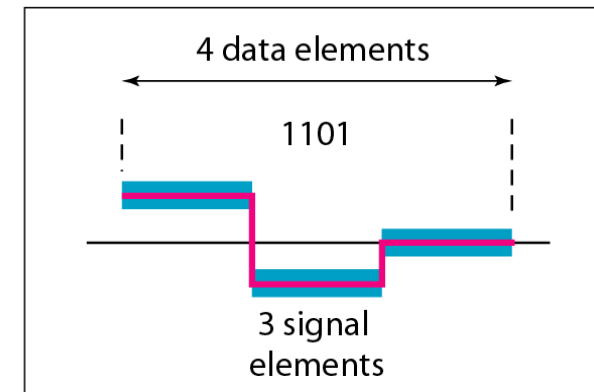

d. Four data elements per three signal elements ($r = \frac{4}{3}$)



Baud rate

The baud or signal rate can be expressed as:

$$S = c \times N \times 1/r \text{ bauds}$$

Where:

N is data rate

c is the case factor (worst, best & avg.)

r is the ratio between data element & signal element

Bipolar - AMI and Pseudo-ternary

- Code uses 3 voltage levels: - +, 0, -, to represent the symbols (note not transitions to zero as in RZ).
- Voltage level for one symbol is at “0” and the other alternates between + & -.
- Bipolar Alternate Mark Inversion (AMI) - the “0” symbol is represented by zero voltage and the “1” symbol alternates between +V and -V.
- Pseudo-ternary is the reverse of AMI.

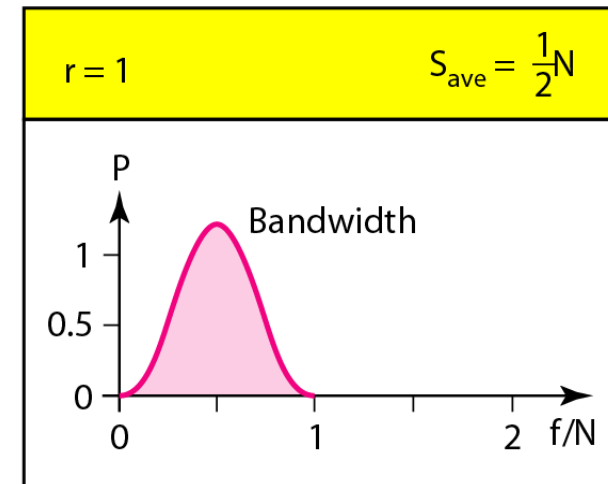
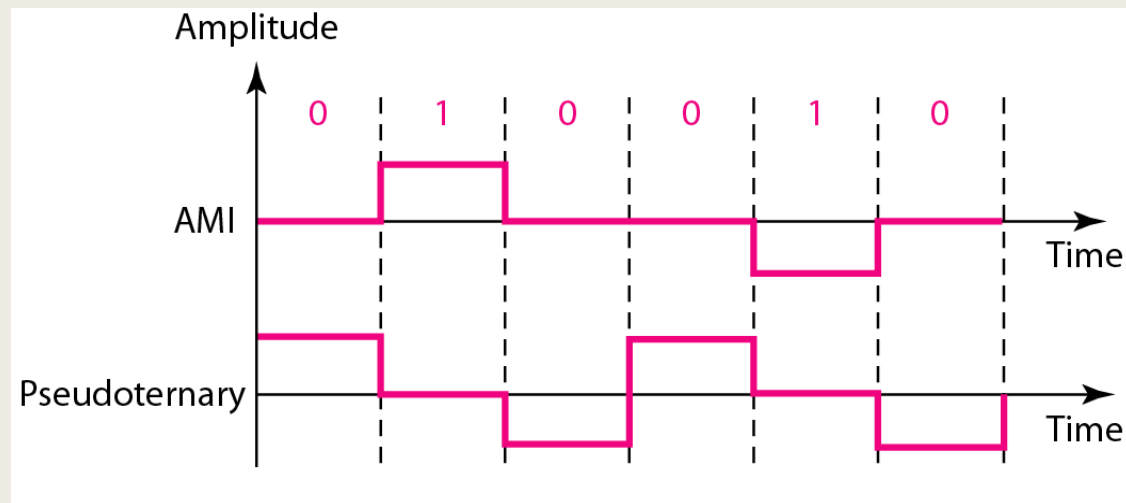

Source: B. A. Forouzan, “ Data Communications and Networking ,” McGraw-Hill Forouzan Networking Series,5E.

B8ZS



- Bipolar With 8 Zeros Substitution
- Based on bipolar-AMI
- If octet of all zeros and last voltage pulse preceding was positive encode as 000+-0-+
- If octet of all zeros and last voltage pulse preceding was negative encode as 000-+0+-
- Causes two violations of AMI code
- Unlikely to occur as a result of noise
- Receiver detects and interprets as octet of all zeros

Thank You!!!